

Installation and Operating Instruction Supplement



Use in conjunction with the original technical literature supplied by Riello

Riello Burner

Gas or Oil-Fired Burner
for use with Vitola 200 boiler

Heating input 83 to 300 MBH
24 to 88 kW

Riello Burner



IMPORTANT

Read and save these instructions for future reference.



⚠ WARNING

If the information in this manual is not followed exactly, a fire or explosion may result causing property damage, personal injury or loss of life.

Do not store or use gasoline or other flammable liquids in the vicinity of this or any other appliance.

WHAT TO DO IF YOU SMELL GAS

- Do not try to light any appliances.
- Do not touch any electrical switches, do not use any phone in your building.
- Immediately call your gas supplier from a neighbor's phone. Follow the gas supplier's instructions.
- If you cannot reach your gas supplier, call the fire department.

Installation and service must be performed by a qualified installer, service agency or the gas supplier.

⚠ WARNING

Improper installation, adjustment, and/or operation could cause carbon monoxide poisoning resulting in injury or loss of life.

This product must be installed and serviced by a professional service technician who is experienced and qualified in hot water boiler installation and gas combustion.

Safety, Installation and Warranty Requirements

Please ensure that this manual is read and understood before commencing installation. Failure to comply with the issues listed below and details printed in this manual can cause **product/property damage, severe personal injury, and/or loss of life**. Ensure all requirements below are understood and fulfilled (including detailed information found in manual subsections).

Each of the following issues is very important and is discussed in detail in the boiler technical literature. Ensure that the installation complies fully and completely with all requirements set out in the boiler technical literature.

■ Licensed professional heating contractor

The installation, adjustment, service, and maintenance of this equipment *must be* performed by a licensed professional heating contractor.

► Please see section entitled "Important Regulatory and Installation Requirements".

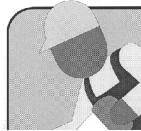

■ Contaminated air

Air contaminated by chemicals can cause by-products in the combustion process which are *poisonous* to inhabitants and destructive to Viessmann equipment.

! WARNING
Do not store chemicals containing chlorine or other corrosive materials near the boiler, such as bleach, cleaning solvents, detergents, acids, hair spray, spray cans, paint thinners, paint, water softener salt, refrigerants, etc.

■ Fresh air

This equipment requires fresh air for safe operation and must be installed ensuring provisions for *adequate combustion and ventilation air* exist.

! WARNING
Never operate the burner without an adequate supply of fresh combustion air. All the combustion and ventilation air must be supplied from the outside. Failure to heed this warning can cause severe personal injury or loss of life.

■ Product documentation

Read all applicable documentation before commencing installation. Store documentation near boiler in a readily accessible location for reference in the future by service personnel.

► For a listing of applicable literature, please see section entitled "Important Regulatory and Installation Requirements".



■ Carbon monoxide

Improper installation, adjustment, service and/or maintenance can cause flue products to flow into living space. Flue products contain *poisonous* carbon monoxide gas.

! WARNING
Installers must follow local regulations with respect to installation of carbon monoxide detectors. Follow manufacturer's maintenance schedule of boiler.

■ Equipment venting

Never operate boiler without an *installed venting system*.

! WARNING
Improper, incomplete, obstructed, or deteriorated vent system can present a serious risk of flue gases leaking into living space which could cause carbon monoxide poisoning.

■ Advice to owner

Once the installation work is complete, the heating contractor must familiarize the system operator/ultimate owner with all equipment, as well as safety precautions/requirements, shut-down procedure, and the need for professional service annually before the heating season begins.

■ Warranty

Information contained in this and related product documentation must be read and followed. *Failure to do so renders warranty null and void.*



	Page
Safety	Important Regulatory and Installation Requirements 4
Set-up	Product Delivery 4
	Mounting Burner 5
	Burner Set-up - Gas 6
	Burner Set-up - Oil 10
	Oil Cartridge Assembly 13
	Burner Set-up - Gas and Oil 13
Start-up/Appendix	Start-up Information 14
	Technical Data 15
	Wiring Diagram 18
	Maintenance Record 20
Operation	Lighting Instructions 23

Important Regulatory and Installation Requirements

 Take note of all symbols and notations intended to draw attention to potential hazards or important product information. These include "WARNING", "CAUTION", and "IMPORTANT".

Codes

The installation of this unit shall be in accordance with local codes. In the absence of local codes, use:

- CSA B-139 for oil installations in Canada
- CSA-B149.1 or .2 for gas installations in Canada
- NFPA 31 Standard for the Installation of Oil Burning Equipment for oil installations in the U.S.
- ANSI Z223.1 National Fuel Gas Code for gas installations in the U.S.

Always use latest editions of codes.

All electrical wiring is to be done in accordance with the latest edition of CSA C22.1 Part 1 and/or local codes. In the U.S. use the National Electrical Code ANSI/NFPA 70. The heating contractor must also comply with the Standard for Controls and Safety Devices for Automatically Fired Boilers, ANSI/ASME CSD-1 where required by the authority having jurisdiction.



Working on the equipment

The installation, adjustment, service, and maintenance of this boiler must be done by a **licensed professional heating contractor** who is qualified and experienced in the installation, service, and maintenance of hot water boilers. There are no user serviceable parts on the boiler, burner, or control.

Ensure **main power** supply to equipment, the heating system, and all external controls has been **deactivated**. **Close main gas or oil supply valve**. Take precautions in both instances to avoid accidental activation of power during service work.

IMPORTANT

Install the boiler as described in its technical documentation before installing or operating the burner.

	 WARNING
	Turn off electric power supply before servicing. Contact with live electric components can cause shock or loss of life.

Product Delivery

Riello burners shipped by Viessmann are factory tested and calibrated on the correct boiler size using combustion analysis equipment.

- Product delivery**
- Carton with gas or oil burner

Mounting Burner

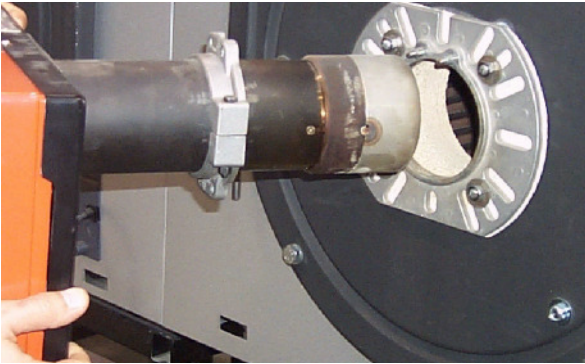

*Fig. 1
Installing burner*

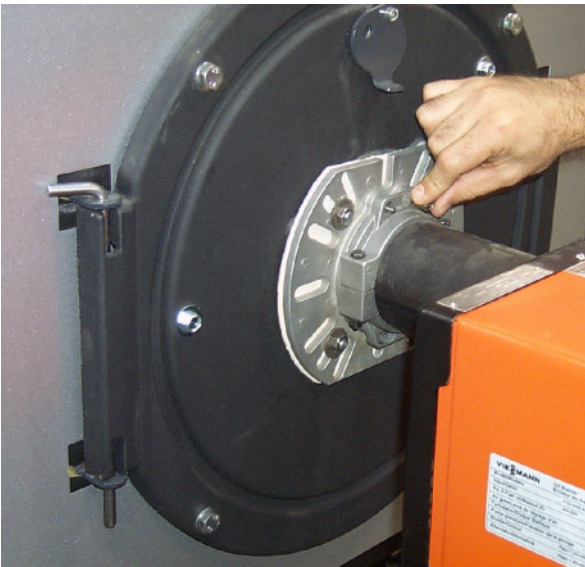

*Fig. 2
Securing burner flange to combustion chamber door*

Installation

1. Remove burner from carton. The universal mounting flange has been installed on the burner at the factory.

2. Mount burner as shown in Figs. 1 and 2.

Burner Set-up - Gas

Installation

The gas train may be mounted on the left or on the right side of burner.

IMPORTANT

G200 burners have a 1/2" NPT female gas connection.

G400 burners have a 3/4" NPT female gas connection.

Gas train

NG flow pressure: min. 4.0" w.c.
max. 10.5" w.c.
LP flow pressure: min. 8.0" w.c.
max. 13.0" w.c.

Gas piping pressure test

The burner and its gas connection must be leak-tested before placing the boiler/burner combination in operation.

The burner and its individual shut-off valve must be disconnected from the gas supply piping system during any pressure testing of that system at pressures in excess of 0.5 psig/3.5 kPa.

Unions and manifold have been factory-tested. Leak test must be repeated during initial operation of burner by heating contractor. **Never** check for gas leaks with an open flame. Use approved spray liquid or soap water solution for bubble test.

Legend (Fig. 3)

- ① Gas supply and gas flow direction
- ② Gas shut-off valve (field supplied)
- ③ Gas supply pressure test point (field supplied)
- ④ Gas train pipe diameter(s)
Burner G200 1/2" NPT
Burner G400 3/4" NPT
- ⑤ Maxitrol RV52 with RV5210-13 (brown spring 1.0 to 3.5" w.c.) gas appliance pressure regulator
- ⑥ Honeywell gas solenoid valve V8295 N.C. (24 V operated)
- ⑦ Dungs MVD-LE model 200
G200 = MVD-LE 205/6 (24 V)
G400 = MVD-LE 207/6 (24 V)
- ⑧ Gas burner manifold test point

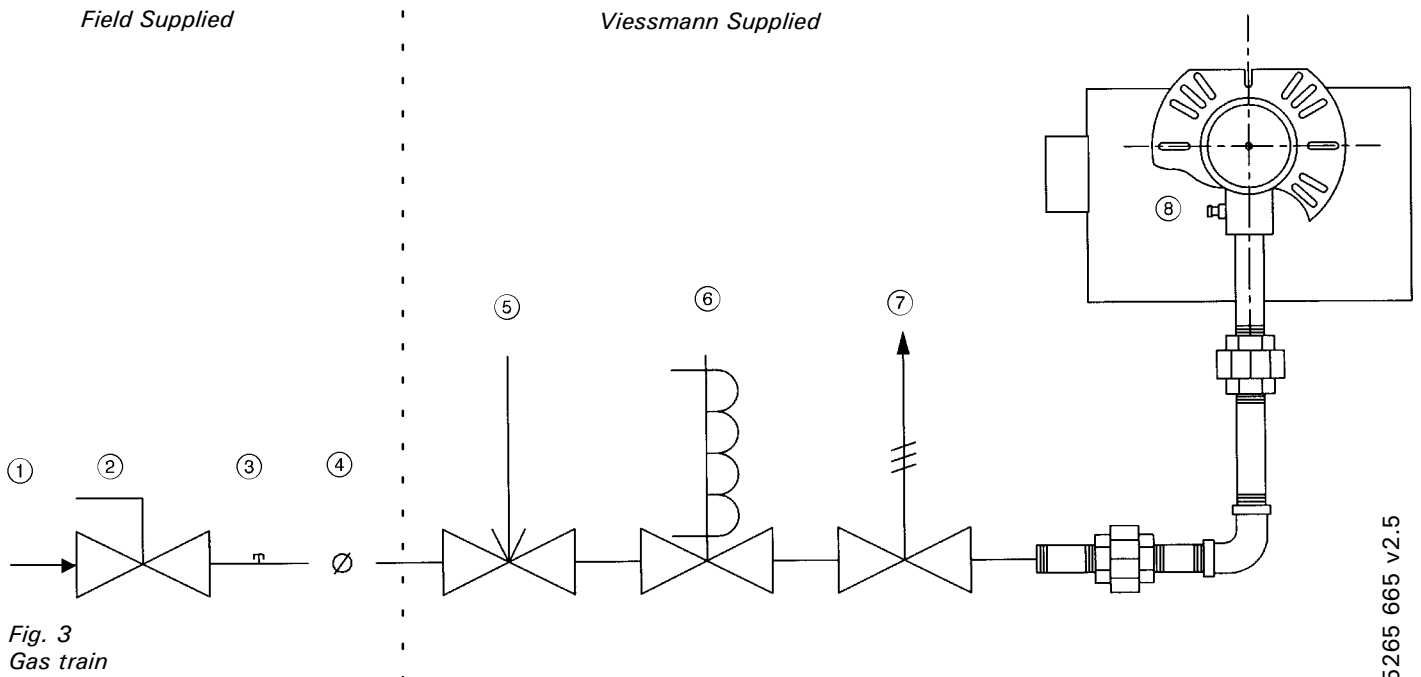

Fig. 3
Gas train

Burner Set-up - Gas (continued)

Burner manifold gas pressure adjustment

IMPORTANT

The burner manifold gas pressure settings must be performed using the RV52 gas appliance regulator only.

In the event of low gas supply pressure, increase gas supply pressure using the RV52 gas regulator to required minimum gas supply pressure.



Operating and Installation Instructions for gas train components (supplied)

IMPORTANT

No preliminary adjustments required for Honeywell V8295 N.C. gas solenoid valve.

Adjustment steps

1. Attach manometer to burner manifold test point (combustion head ⑧).
2. Start up burner and observe.
3. Wait until burner has stabilized to adjust burner manifold pressure using the RV52 gas appliance regulator, and set to required burner manifold pressure setting. Use factory default settings (pages 15 and 16) as starting point only.
4. To adjust the initial lift gas pressure remove sealing cap, exposing the lift adjustment knob, turn over cap, adjust knob to "+" to increase the start pressure and set to approx. 0.7 to 0.9 "w.c. (manifold pressure).

IMPORTANT

Factory default setting is set to 100% full flow.

5. Restart appliance at least three times to finalize gas manifold setting and to determine a smooth ignition.
6. If burner fails to ignite or ignition is delayed or hard, one or more of the following corrective actions may be required:
 - Adjust initial gas pressure setting on Dungs gas valve.
 - Ignition electrode and/or ionization (flame) rod is not set within specified range, adjust setting by referring to original Installation Instructions of Riello burner.

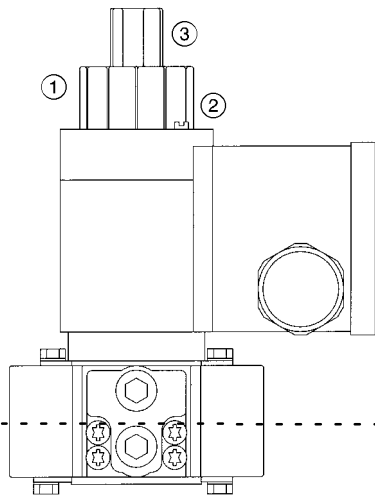

Fig. 4
MVD-LE valve, side view

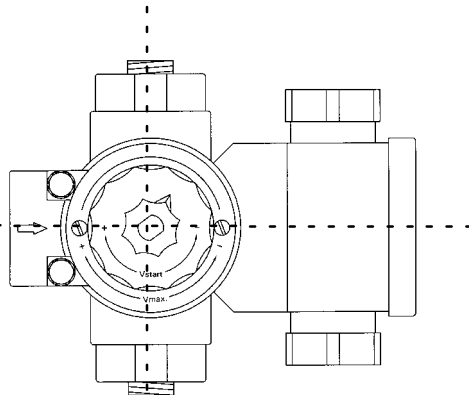

Fig. 5
MVD-LE valve, top view

- ① Flow adjustment cap
- ② Pan head screw
- ③ Sealing cap/adjustment cap tool

Burner Set-up - Gas (continued)

Verifying input of gas boilers

Natural gas burners must have gas input clocked using the gas meter. Ensure there is no gas flowing through the meter other than to the gas-fired boiler being checked. See pages 15 and 16 for gas flow rate and values for time (in seconds) for clocking gas meter. Clock at least 10 revolutions on a one ft³ gas meter dial and divide time by 10. The value arrived at should be the same as shown on pages 15 and 16.

IMPORTANT

If necessary, manifold pressure must be adjusted to make sure burner is firing at nominal input. Do not exceed gas input stated on rating plate. Turn adjustment screw on gas pressure regulator (RV52) clockwise to increase gas flow, and counterclockwise to decrease gas flow (as per instructions on the previous page).

If checking gas input with a manometer only use manifold pressures given in manual as a starting point, and use combustion instruments to ensure safe and efficient combustion values.

Be sure to turn gas off before attaching or removing pressure taps. All plugs removed for the purpose of gas pressure measurements must be replaced and leak-tested after measurements.

! WARNING

Each Riello gas burner has a different manifold pressure. When replacing a gas valve, a manometer and instruments measuring combustion must be used to ensure burner is operating safely at its designed input. An overfired burner is unsafe and can cause severe personal injury or loss of life if products of combustion are allowed to enter living space through incorrect procedures.

Replacement of 24V gas valve

Use only replacement gas valves from Viessmann Manufacturing. The 24 VAC Dungs 3/4" MVD-LE 207/6 and 1/2" MVD-LE 205/6 direct spark valves are special valves designed to operate at the low manifold pressures required by the Riello burner for both natural and propane gas. Do not use other gas valve unless specified by Viessmann.

Field measured combustion results

Use the combustion data label packed with the gas burner to record field measured combustion results and affix label to gas burner.

Adjustment data tag ANSI Z21-17b-1994		
Input: C.F.H.		
Manifold pressure		
Air damper		
Air/gas ratio No.		
Flue gas temp.		
O ₂ level: %		
CO ₂ level: ppm		
Date		
Completed by		
Installing contractor		

! WARNING

Checking for a safe concentration of carbon monoxide (below 50 ppm air-free) will ensure continual safe operation of boiler and burner. Annual maintenance and cleaning as described in this manual must be done. Failure to heed this warning may lead to severe personal injury or loss of life.

IMPORTANT

It is necessary to follow all safety information in the Riello technical literature as well as all other OEM component instructions shipped with this manual. The Viessmann factory settings are an initial guide to be verified or changed by the installer based on field measured combustion results. The burner settings arrived at during field measurements may be different from the generalized conversion burner settings given in the Riello technical literature.

Burner Set-up - Gas (continued)

IMPORTANT

Note the following construction differences between the general Riello conversion burner and Riello burner supplied for use on the Vitola boiler.

N200 and P200 burners for use with Vitola 200 VB2-18 to VB2-40

The 40-(N,P)200 gas burners when supplied by Viessmann for VB2-18 and -22 are constructed with drawer assembly diaphragm installed in the combustion head assembly for natural gas and propane.

The main gas orifice for natural gas is changed from the 2.0 mm orifice normally supplied with a 40-(N,P)200 aftermarket conversion burner to that stated in the table below.

The differences in orifice size for the VB2-18, -22 cause the manifold pressure adjustment information in the Riello 40-(N,P)200 manual to be not applicable. Use the manifold pressures in this manual as a starting point for burner adjustment for the VB2-18, -22. Do not change orifice, diaphragm or sleeve-combination. Contact the Viessmann Technical Department.

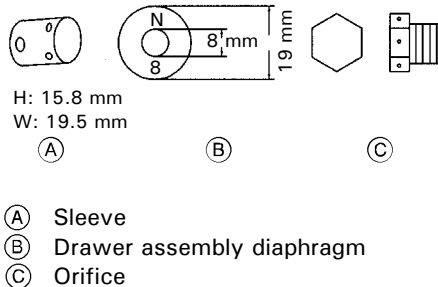

Summary of changes to original Riello burner

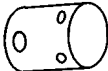
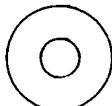
Burner Model	Model No. Boiler	G200 VB2-18	G200 VB2-22	G200 VB2-33	G200 VB2-40
Orifice 	NG	1.5	1.7	2.0	2.0
	LP	1.3	1.3	1.3	1.3
Sleeve 	NG	n.a.	installed	installed	n.a.
	LP	installed	installed	installed	installed
Diaphragm 	NG	installed	installed	n.a.	n.a.
	LP	installed	installed	n.a.	n.a.

n.a. = not applicable

Burner Set-up - Oil



Fig. 6
Connection to a one-pipe system

The oil burner is provided with its own oil filter and built-in flow check valve. The flow check valve is located in the return, and a manual shut-off is located in the supply.

One-pipe systems

1. Connect as shown in Fig. 6.

Burner Set-up - Oil (continued)



Fig. 7
Side-mounting support bracket



Fig. 8
Front-mounting support bracket



Fig. 9
Mounting filter and check valve assembly

2. Mount filter support bracket either on the side of the boiler (Fig. 7) or on the front of the boiler (Fig. 8).

3. Mount filter and check valve assembly to mounting bracket (Fig. 9).

Filter is disposable type and must be replaced with the filter cartridge supplied by Viessmann.

Burner Set-up - Oil (continued)



4. Connect flexible oil lines to the filter check valve assembly. See Fig. 10.

Red: supply (connection with the red manual valve)

Blue: return (connection with the check valve).

Fig. 10
Connect oil supply and return lines

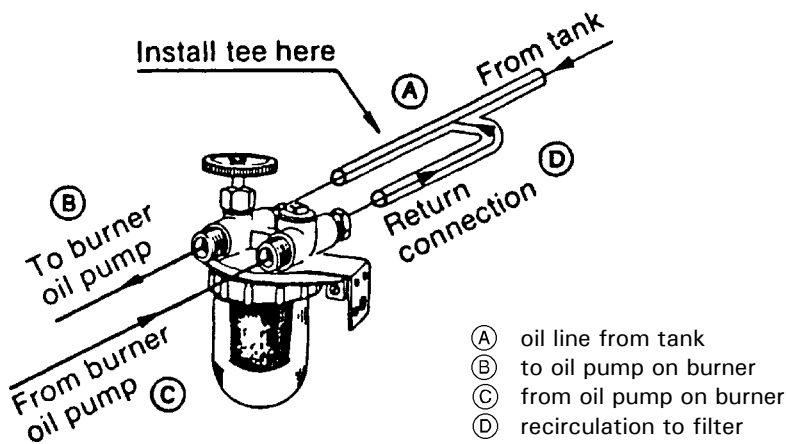

The Riello burner shipped by Viessmann comes with the bypass plug already installed, ready for two-pipe connection. For a one-pipe system (gravity system where the oil tank is above the burner) use the copper tee provided. This tee converts the two-pipe system to a one-pipe system. The oil not used by the pump recirculates into the supply line. Pipe sealant must be used on the threaded ends of the flare fittings which join the copper tee to the filter check valve assembly.

5. Install tee as shown in Fig. 11.

Fig. 11
Converting two-pipe system to one-pipe system

Oil Cartridge Assembly

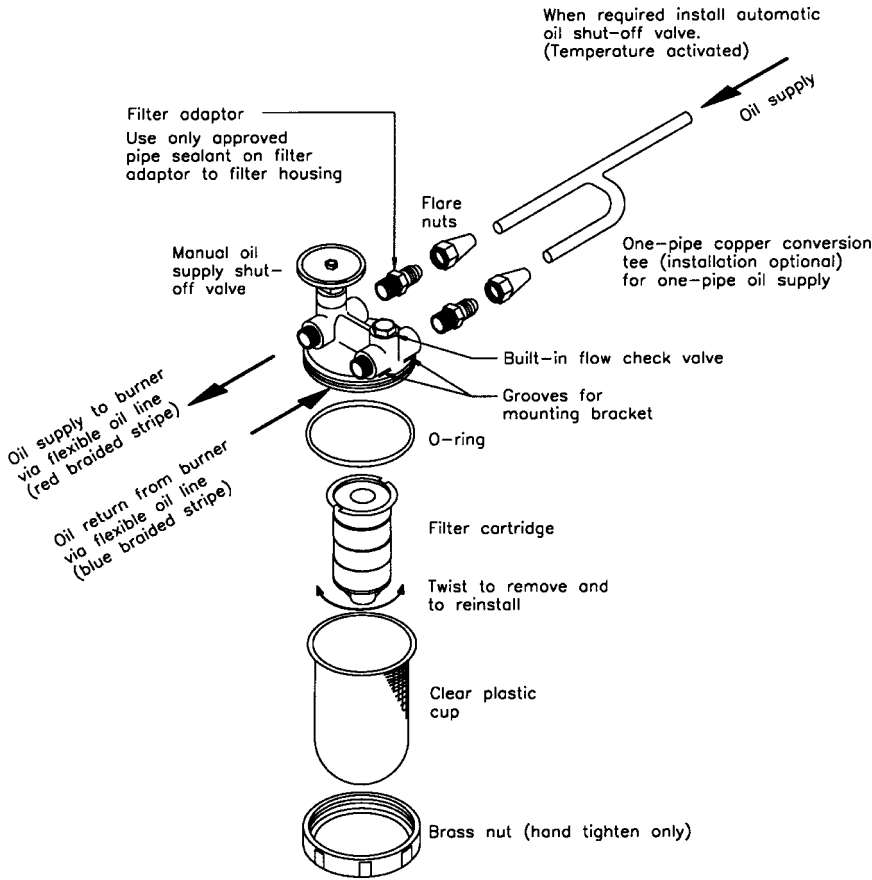

Fig. 12
Oil cartridge assembly

1. Check that all surfaces are clean before installing new O-ring supplied with replacement filter cartridge.
2. Set O-ring in place and mount new filter cartridge.
3. Attach clear plastic cup and tighten brass nut.

IMPORTANT

Never tighten brass nut with a tool; hand tighten only. Cap and O-ring might deform and leak air.

IMPORTANT

The flare adaptors are tapped 3/8" BSP (British straight pipe) at the factory. Replacement flare adaptors must be ordered from Viessmann. Do not use 3/8" NPT flare adaptor as replacement.

CAUTION

When new cartridge assembly is mounted, remove brass nut and plastic cup. Check for clean and proper O-ring and O-ring seats before starting oil flow.

CAUTION

Never use Teflon tape or compression fittings in fuel oil piping.

Burner Set-up - Gas and Oil



5265 665 v2.5

Fig. 13
The quick-connect plug-in system

IMPORTANT

Refer to Riello instructions for adequate fuel supply pipe sizing and sequence of burner operation.
Ensure an adequate supply of fresh combustion and ventilation air for safe operation.
Refer to codes mentioned on page 4.

Electrical connections

1. Run the 41 plug-in connector cable of the Vitotronic control down behind the front panel of the boiler and out through the wire strain relief as per the boiler installation instructions (Electrical Connections).
2. Connect the female 41 plug of the burner to the male 41 plug of the Vitotronic control. See Fig. 13.



Installation Instructions
Riello gas or oil burner

Start-up Information

Boiler start-up



Start-up/Service Instructions of boiler, as well as literature of burner, burner test sheet and control literature.

Combustion analysis

This gas or oil burner requires combustion measurements to be performed at the final installation site by a licensed heating contractor to verify factory settings, or to be used as a guide in changing burner settings to suit local conditions.

Examples of local conditions which influence combustion results include: weather conditions, length of horizontal vent pipe, diameter and height of the chimney, side wall venting (power vent), altitude above sea level, quality and heating value of gas or oil used, maximum number of other fuel burning appliances running at the same time. These conditions affect the burner set-up. The burner must be adjusted for acceptable combustion results under local conditions of the installation.

IMPORTANT

When the boiler is fired for the first time, the ceramic fiber insulation at the back of the combustion chamber door will require ½ to 1 hour of firing time to “cure”. An odor may occur during this time. Final measurements of CO must be done only after the “cure” is complete.

Combustion measurements (CO₂, stack temperature, draft and CO) are taken in the flue pipe between boiler and barometric draft regulator before dilution air (see the installation manual). Overfire draft is measured at the combustion chamber observation port opening. The expected CO₂ products of combustion are printed below. These values are based on average results - slightly higher or lower values may be suitable depending on installation conditions.

Fuel	NG	LP	Oil
CO ₂	9.5 to 10.2%	10.0 to 11.5%	11.0 to 13.0%

The CO concentration should be as shown on the Viessmann quality control burner test results. If the CO concentration is above 50 ppm, then measures should be taken to decrease concentration to a value below 50 ppm. Steps to be taken include: ensuring sufficient supply of combustion air, adjusting air gate settings, ensuring chimney and vent are correct and meet safety codes, verifying boiler input and burner settings, replacing any defective part on burner, contacting manufacturer’s technical sales representative for assistance.

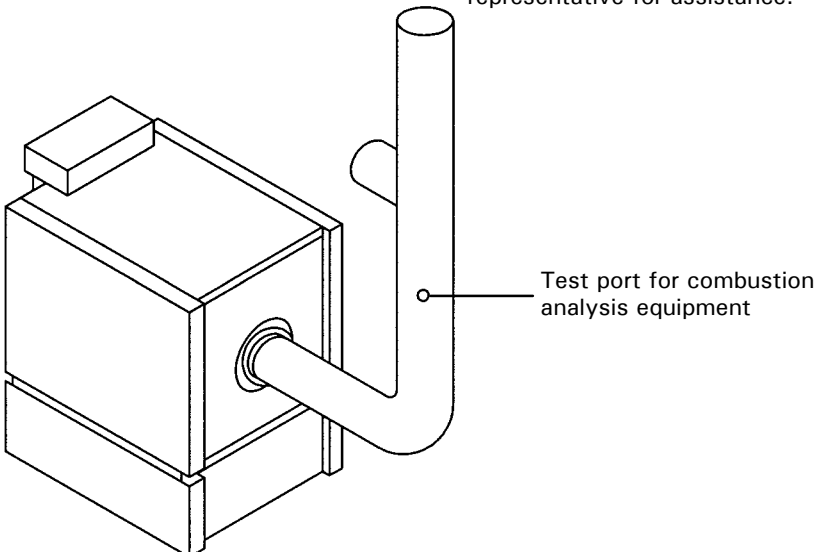

! WARNING
DO NOT USE GASOLINE CRANKCASE DRAININGS OR ANY OIL CONTAINING GASOLINE.

! WARNING
Always keep the manual fuel supply valve shut off if the burner is shut down for an extended period of time.

! WARNING
Do not tamper with the unit or controls.

! WARNING
DO NOT START THE BURNER UNLESS THE COMBUSTION CHAMBER DOOR IS SECURED IN PLACE.

! WARNING
DO NOT ATTEMPT TO START THE BURNER WHEN EXCESS OIL HAS ACCUMULATED, WHEN THE UNIT IS FULL OF VAPOR, OR WHEN THE COMBUSTION CHAMBER IS VERY HOT.

Technical Data

Natural gas

Burner Model	Boiler	N200 VB2-18	N200 VB2-22	N200 VB2-33	N200 VB2-40	N400 VB2-50	N400 VB2-63
Input	MBH	90	116	146	185	238	300
	kW	26	34	42	54	69	88
Flow Rate	ft ³ /h	90	116	146	185	238	300
	m ³ /h	2.55	3.29	4.13	5.24	6.74	8.5
Gas Valve	Model	MVD-LE 205/6	MVD-LE 205/6	MVD-LE 205/6	MVD-LE 205/6	MVD-LE 207/6	MVD-LE 207/6
Manifold Pressure	"w.c.	1.6	2.1	2.0	1.5	1.2	1.1
T in seconds	1 ft ³	40.00	31.03	24.65	19.45	15.12	12.00
	0.01 m ³	14.1	10.86	8.70	6.86	5.34	4.23
Combustion Head Setting		0.3	2.0	2.0	3.5	1.0	5.0
Air Gate Setting		2.0	2.0	2.8	3.5	2.5	2.8

The above specifications are for 0-2000 ft. above sea level.

CAUTION

The burner settings above do not guarantee safe operation. Burner settings serve to help provide smooth operation at initial start-up.

CAUTION

Do not overfire or underfire burner. Factory settings to be verified or changed by qualified heating contractor, depending on field measured combustion results.

Burner test results

The indicated values for manifold and air gate settings are the result of production line testing under ideal conditions.

Final burner adjustment to suit local field conditions is necessary for safe operation.

IMPORTANT

Observe the stated minimum and maximum supply gas pressures. Exposing the burner gas train to supply pressures other than the stated values can cause unsafe conditions.

Viessmann strongly recommends the installation of an approved type CO detector in the vicinity of any gas burning equipment. Observe national and/or local code requirements. If in doubt consult your local gas company.

Verification of results

The burner adjustment values indicated serve as a starting point only. Combustion results must be field verified using properly calibrated Bacharach or equivalent instruments. Each burner is certified for one input only. Do **not** overfire or underfire burner.

Technical data

Fuel natural gas
Average heating value 1000 MBH/ft³

Specifications

Inlet gas pressure min. 4.0" w.c.
max. 10.5" w.c.

Draft regulator

VB2-18 to -40 MG1 6"
VB2-50 to -63 MG1 7"
Overfire draft +0.01" w.c.
Max. breeching draft -0.02" w.c.

INPUT = 3600/T x 1000

where

T = TIME (sec.) for 1 ft³ natural gas

INPUT = (3600 x 0.01 x 1000 x 35.31)/T
where

T = TIME (sec.) for 0.01 m³ natural gas

Technical Data (continued)

Liquid propane

Burner Model	Boiler	P200 VB2-18	P200 VB2-22	P200 VB2-33	P200 VB2-40	P400 VB2-50	P400 VB2-63
Input	MBH kW	90 26	116 34	146 42	185 54	238 69	300 88
Flow Rate	ft ³ /h m ³ /h	36 1.02	46.4 1.31	58.4 1.65	74 2.10	95.2 2.70	120 3.40
Gas Valve	Model	MVD-LE 205/6	MVD-LE 205/6	MVD-LE 205/6	MVD-LE 205/6	MVD-LE 207/6	MVD-LE 207/6
Manifold Press.	"w.c.	1.2	1.4	1.6	2.4	1.3	1.7
T in seconds	1 ft ³ 0.01 m ³	100 35.31	77.58 27.40	61.64 21.76	48.62 17.17	37.80 13.35	30.00 10.59
Combustion Head Setting		0.5	2.0	3.0	3.5	1.0	5.0
Air Gate Setting		2.0	2.0	2.75	3.75	2.4	2.8

The above specifications are for 0-2000 ft. above sea level.

CAUTION
The burner settings above do not guarantee safe operation. Burner settings serve to help provide smooth operation at initial start-up.

CAUTION
Do not overfire or underfire burner. Factory settings to be verified or changed by qualified heating contractor, depending on field measured combustion results.

Burner test results

The indicated values for manifold and air gate settings are the result of production line testing under ideal conditions.

Final burner adjustment to suit local field conditions is necessary for safe operation.

IMPORTANT

Observe the stated minimum and maximum supply gas pressures. Exposing the burner gas train to supply pressures other than the stated values can cause unsafe conditions. Viessmann strongly recommends the installation of an approved type CO detector in the vicinity of any gas burning equipment. Observe national and/or local code requirements. If in doubt consult your local LP company.

Verification of results

The burner adjustment values indicated serve as a starting point only. Combustion results must be field verified using properly calibrated Bacharach or equivalent instruments. Each burner is certified for one input only. Do not overfire or underfire burner.

Technical data

Fuel propane gas
Average heating value 2500 MBH/ft³

Specifications

Inlet gas pressure min. 8" w.c.
max. 13" w.c.
Draft regulator
VB2-18 to -40 MG1 6"
VB2-50 to -63 MG1 7"
Overfire draft +0.01" w.c.
Max. breeching draft -0.02" w.c.

INPUT = 3600/T x 2500
where
T = TIME (sec.) for 1 ft³ propane gas
INPUT = (3600 x 0.01 x 2500 x 35.31)/T
where
T = TIME (sec.) for 0.01 m³ propane gas

Technical Data (continued)

Fuel oil No. 2

Burner Model	Boiler	F3 VB2-18	F3 VB2-22	F5 VB2-33	F5 VB2-40	F10 VB2-50	F10 VB2-63
Input	MBH kW	83 24	107 31	135 39	170 50	219 64	300 88
Nozzle	Danfoss	n.a.	n.a.	0.85x60°xAH	1.00x60°xAH	n.a.	n.a.
	Delavan	0.50x60°xSS	0.60x60°xA	0.85x60°xW	1.00x60°xW	n.a.	n.a.
	Hago	0.50x60°xB	0.60x60°xB	n.a.	n.a.	1.25x60°xB	1.65x45°xB 1.65x45°xSS
	Steinen	n.a.	n.a.	n.a.	n.a.	n.a.	1.65x45°xS
Nozzle Flow	USGPH	0.59	0.76	0.96	1.21	1.56	2.14
	MBH	83	107	135	170	219	300
Pump Pressure	psig	150	170	145	170	165	175
	kPa	1034	1172	1000	1122	1138	1207
Air Tube Length	inches	10	10	10	10	10	10
	mm	254	254	254	254	254	254
Air Tube Insertion	inches	9 3/4	9 3/4	9 3/4	5 3/4	5 3/4	5 3/4
	mm	248	248	248	146	146	146
See Fig. 14, dimension "a"							
Turbulator		2	3	3	4	1	4
Air Gate		2.75	3.5 - 3.75	3.0	3.5	3.0	4.0

IMPORTANT

In multiple-boiler installations, a booster pump may be required.

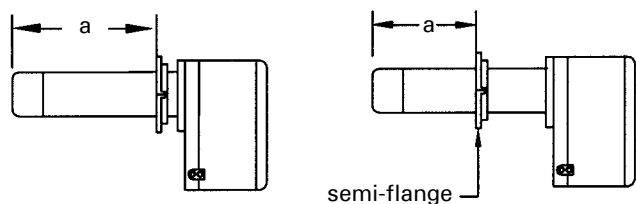

Fig. 14
Air tube insertion
(VB2-18, -22, -33)

(VB2-40, -50, -63)

F10 burners for use with Vitola 200 VB2-50, VB2-63

The F10 as supplied by Viessmann uses the 10" long tube and a special turbulator disc and end cone unique to Viessmann. Order replacements from Viessmann only.

Wiring Diagram

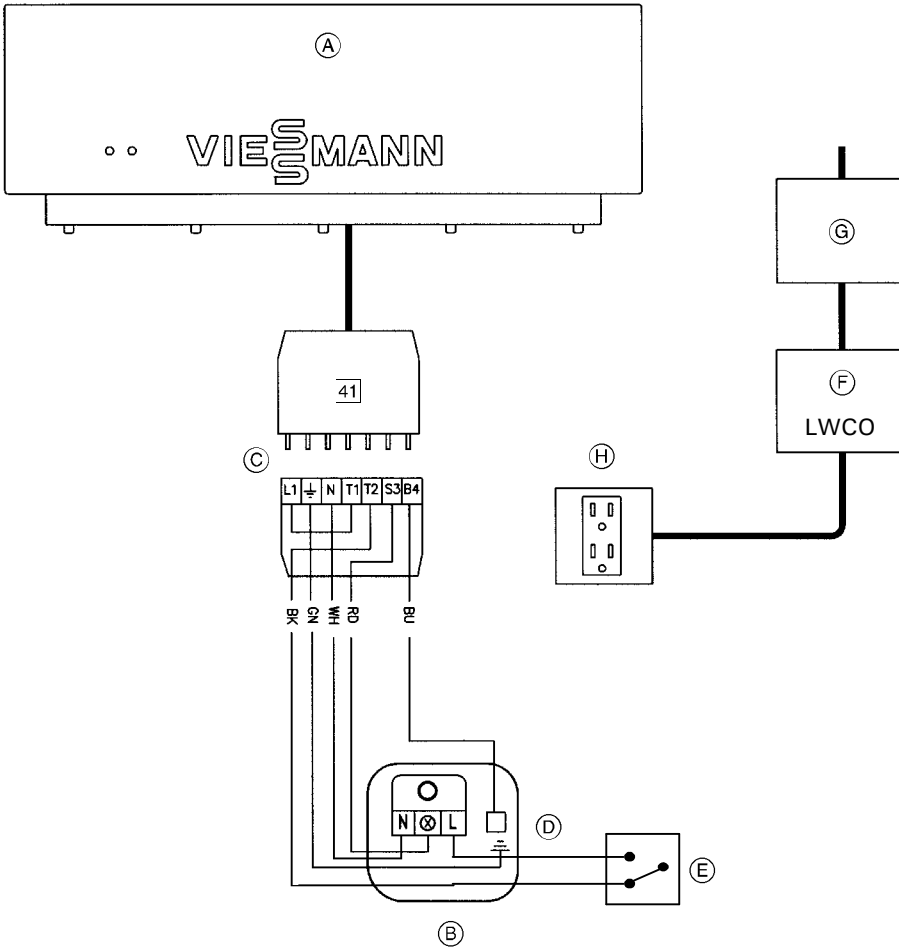

- Ⓐ Vitotronic boiler control
- Ⓑ Riello burner
120 VAC, 60 Hz, 2.5 A
- Ⓒ Burner 41 plug-in connector
(male and female)
- Ⓓ Primary control connections;
*connect blue wire to the following
terminal on the control box:*

Fuel	NG	LP	Oil
Terminal	7	7	6

- Ⓔ Motorized air damper (gas burner
only)
- Ⓕ Low water cut-off
(field supplied, if required)
- Ⓖ Heating system ON/OFF switch
120 VAC, installer must provide
15 A overcurrent protection
- Ⓗ Receptacle (site)
120 VAC

! WARNING
Turn off electric power supply before servicing. Contact with live electric components can cause shock or loss of life.

! WARNING
Safety high limit aquastats are inside boiler control. Do not operate burner without boiler control. Never bypass aquastats.

! CAUTION
Label all wires prior to disconnection when servicing controls. Wiring errors can cause improper and dangerous operation. Verify proper operation after servicing.

IMPORTANT

Install the boiler as described in its technical documentation before installing or operating the burner.

IMPORTANT

120 VAC is supplied to burner via 41 plug-in connector. Do not connect additional 120 VAC to burner.

IMPORTANT

If any of the original wires as supplied with the appliance must be replaced, replace with 221°F/105°C rated or its equivalent. Minimum size 18 AWG.

Installation of Blocked Vent Safety Switch (for Canadian oil burning installations only)

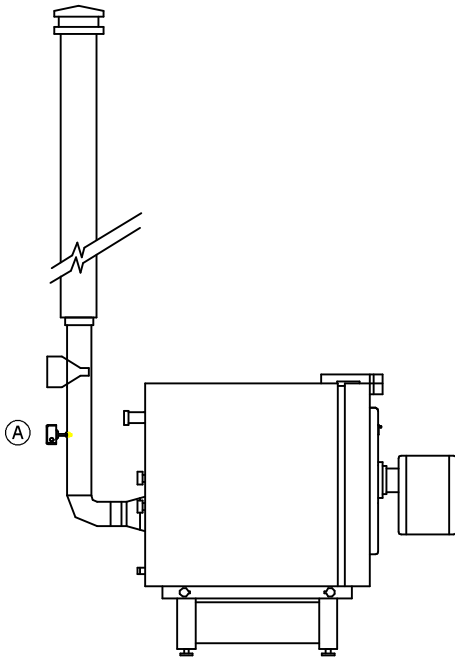

CAUTION
 For use with chimney venting only. Do not use in conjunction with sidewall power venting or direct vent application. These venting systems will provide a safety shutdown in case the vent system becomes blocked.

IMPORTANT
 There are additional parts supplied in this kit. Refer to appropriate page for specific instructions on burner/boiler combination.

1. Install blocked vent switch (A) (see enclosed FieldControls WMO-1 Installation Instructions).
2. Run BX cable (armored cable) or any other approved wire (required by local authorities having jurisdiction) from WMO-1 switch to burner base. Use nominal 1/2" electrical knockout provided on Riello plate for connectors. If necessary, relocate [41] wiring harness strain relief to other electrical opening provided.
3. Disconnect black wire (BK) of 7-pole [41] plug from oil burner primary control base.
4. Rewire (wire nut included) the black wire (BK) through WMO-1 safety switch and back to terminal "L" of the oil burner primary control.

VITOTRONIC CONTROL (refer to corresponding Vitotronic controls manual)

120V IS SWITCHED TO BURNER THROUGH 7-POLE PLUG. DO NOT CONNECT ADDITIONAL 120V POWER TO BURNER.

SAFETY HIGH LIMIT AQUASTATS ARE INSIDE BOILER CONTROL. DO NOT OPERATE BURNER WITHOUT BOILER CONTROL NEVER BYPASS AQUASTATS.

CAUTION: Label all wires prior to disconnection when servicing controls. Wiring errors can cause improper and dangerous operation. Verify proper operation after servicing.

WARNING! DISCONNECT POWER BEFORE SERVICING BOILER

If any of the original wire as supplied with the appliance must be replaced, it must be replaced with 221 °F / 105 °C rated or its equivalent. Minimum size 18 AWG.

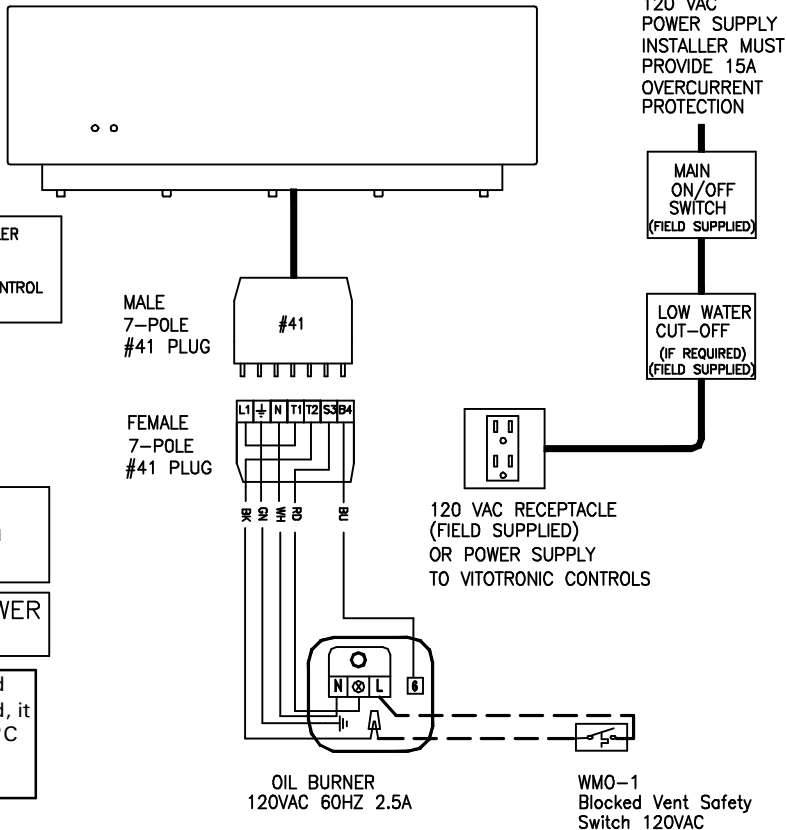

Legend

BK	Black
BU	Blue
GN	Green
RD	Red
WH	White

5265 665 v2.5

----- 120 VAC field wiring

Maintenance Record

	Start-up	Maintenance/Service	Maintenance/Service	Maintenance/Service	Maintenance/Service
on:					
by:					

	Maintenance/Service	Maintenance/Service	Maintenance/Service	Maintenance/Service	Maintenance/Service
on:					
by:					

Service binder

1. File all Parts Lists, Operating and Service Instructions in the Service Binder.
2. Install a protective hanging case near the boiler and store the Service Binder in this location.

Maintenance

Before each heating season begins, have the following service and maintenance done by a licensed, professional heating contractor:

1. Boiler heat exchanger inspected and cleaned.
2. Vent system inspected for deterioration, leaks, corrosion, proper draft, and proper operation. Check vent system for compliance with local and national code requirements. Repair or replace as required.
3. Burner checked and, if necessary, adjusted for proper combustion and operation. Check for adequate supply of fresh outside combustion and ventilation air.

 WARNING
Neglecting to perform necessary maintenance can cause unsafe operation.

Notes

Notes

Lighting Instructions

FOR YOUR SAFETY READ BEFORE OPERATING

W A R N I N G: If you do not follow these instructions exactly, a fire or explosion may result causing property damage, personal injury or loss of life.

- A. This appliance does not have a pilot. It is equipped with an ignition device which automatically lights the burner. Do not try to light the burner by hand.
- B. **BEFORE OPERATING** smell all around the appliance area for gas. Be sure to smell next to the floor because some gas is heavier than air and will settle on the floor.
- WHAT TO DO IF YOU SMELL GAS**
- Do not try to light any appliance.
 - Do not touch any electric switch; do not use any phone in your building.
 - Immediately call your gas supplier from a neighbor's phone. Follow the gas supplier's instructions.
 - If you cannot reach your gas supplier, call the fire department.
- C. Use only your hand to push in or turn the gas control knob. Never use tools. If the knob will not push in or turn by hand, don't try to repair it, call a qualified service technician. Force or attempted repair may result in a fire or explosion.
- D. Do not use this appliance if any part has been under water. Immediately call a qualified service technician to inspect the appliance and to replace any part of the control system and any gas control which has been under water.

OPERATING INSTRUCTIONS

1. **STOP!** Read the safety information above on this label.
2. Set thermostat or other operating control to lowest setting.
3. Turn off all electric power to the appliance.
4. This device is equipped with an ignition device which automatically lights the burner. Do not try to light the burner by hand.
5. Close main gas shut-off valve.
6. Wait five (5) minutes to clear out any gas. Then smell for gas, including near the floor. If you smell gas, **STOP!** Follow "B" in the safety information above on this label. If you don't smell gas, go to the next step.
7. Open main gas shut-off valve.
8. Turn on all electric power to the appliance.
9. Set thermostat or other operating control to desired setting.
10. If the appliance will not operate, follow the instructions "To Turn Off Gas To Appliance" and call your service technician or gas supplier.

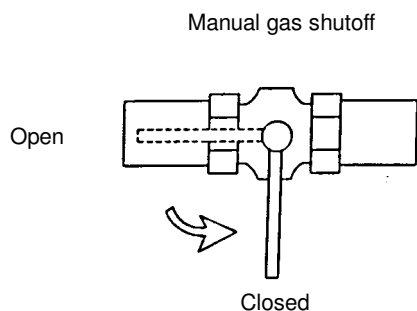

TO TURN OFF GAS TO BOILER

1. Set thermostat or other operating control to lowest setting.
2. Turn off all electric power to the appliance if service is to be performed.
3. Close main gas shut-off valve.

Conversion Table

- "w.c. x 2.54 = mbar
- mbar x 0.394 = "w.c.
- kW x 3413 = Btu
- bar x 14.5 = psig
- kg x 0.289 = USG (#2 oil)
- BHP x 9.8 = kW
- BHP x 33779 = Btu
- m x 3.28 = ft.
- m³ x 35.3 = ft.³
- kcal x 3968 = Btu
- Cal value NG = 950 - 1050 Btu/ft.³
- Cal value LP = 2450 - 2500 Btu/ft.³
- Motor kW x 1.31 = Motor HP

NG Natural Gas

LP Liquid Propane

Quick Reference

°C	°F
-40	-40
-35	-31
-25	-13
-20	-4
-18	0
-16	+3
-14	+7
-12	+10
-10	+14
-9	+16
-8	+18
-7	+19
-6	+21
-5	+23
-4	+25
-3	+27
-2	+28
-1	+30
0	+32
+1	+34
+2	+36
+3	+37
+4	+39
+5	+41
+6	+43
+7	+45
+8	+46
+9	+48
+10	+50
+12	+54
+14	+57
+16	+61
+18	+64
+20	+68
+25	+77
+30	+86
+35	+95
+40	+104
+50	+122
+60	+140
+70	+158
+80	+176
+90	+194
+100	+212
+110	+230

Printed on environmentally friendly
(recycled and recyclable) paper.



Technical information subject to change without notice.